



TimberTech® Closed-Joint Cladding Install Guide

Tools Required	2
Products	3
Installation Preparation	3
Expansion and Contraction.....	4
Fasteners	4
Fastening Schedule	5
Horizontal Application	6-8
Vertical Application	9-11
Storage & Handling, Considerations.....	12
Care and Maintenance.....	13

TOOLS REQUIRED

TimberTech® Closed-Joint Cladding should be installed using good building principals and in accordance with local building codes and the installation guidelines included below. AZEK® Building Products LLC and its affiliates, successors and assigns accepts no liability or responsibility for the improper installation of this product. TimberTech Closed-Joint Cladding may not be suitable for every application and it is the sole responsibility of the installer to be sure any products are a fit for the intended use. Since all installations are unique, it is also the installer's responsibility to determine specific requirements for each application. AZEK recommends that all applications be reviewed by a licensed architect, engineer or local building official before installation. If you have any questions or need further assistance, please call AZEK Customer Service at 1-800-901-3545 or visit our website at www.AZEKexteriors.com.

Tools Required

TimberTech Closed-Joint Cladding can be installed with a minimum number of readily available tools. Many other tools are available that can be used for installation. All tools should be used per applicable manufacturers' instructions. Some of the basic tool requirements:

- Cordless Driver
- Carpenter Square
- Chalk Line
- Spacing Tools
- Tape Measure
- Miter Saw
- Jig Saw
- Chalk Line/String
- Level
- Safety Glasses

Use the jigsaw to cut around obstruction. For best results when cutting, use a power miter saw with a fine-toothed, carbide tipped finish trim blade (12" - 100 tooth min. or 10" - 80 tooth min. A metal cutting saw and carbide tipped saw blade are recommended for best results when cutting steel channel furring. When working with AZEK products be sure to wear proper clothing and safety equipment. Safety glasses should be used during the entire installation process. Do not use any cordless saws.



Extreme Heat Warning

Be aware of excessive heat on the surface of AZEK products from external sources, such as but not limited to, fire or reflection of sunlight from energy-efficient window products. Low-emissivity (Low-E) glass can potentially harm AZEK products. Low-E glass is designed to prevent passive heat gain within a structure and can cause unusual heat build-up on exterior surfaces. This extreme elevation of surface temperatures, which exceeds that of normal exposure, can possibly cause AZEK products to melt, sag, warp, discolor, increase expansion/contraction, and accelerate weathering.

Current or potential AZEK customers that have concerns about possible damage by Low-E glass should contact the manufacturer of the product which contains Low-E glass for a solution to reduce or eliminate the effects of reflected sunlight.



Non Load Bearing Only

TimberTech Closed-Joint Cladding is a non-structural cladding and cannot be used as a load bearing component of the wall.



Important

The outside wall of structure must be weather tight and up to code with a proper weather-resistant barrier or other weather-proofing product prior to installing TimberTech Closed-Joint Cladding. TimberTech Closed-Joint Cladding is not designed for nor intended to prevent water infiltration. It is the sole responsibility of the engineer, architect, and installer to ensure the design and installation of the wall and building are code compliant and weather-resistant behind TimberTech Closed-Joint Cladding.

Products

TimberTech® Closed-Joint Cladding Products

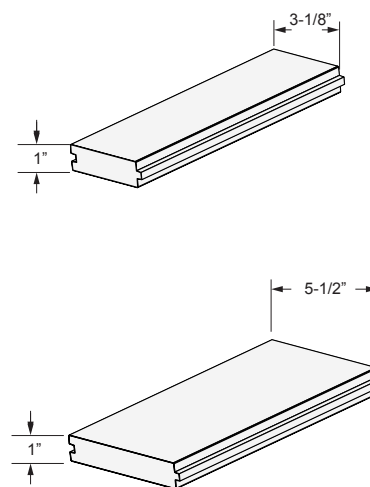

CLOSED-JOINT CLADDING PRODUCTS	5 1/2" WIDTH		3 1/8" WIDTH	
	12'	16'	12'	16'
Standard Thickness 1"				
COASTLINE®	•	•	•	•
WEATHERED TEAK®	•	•	•	•
MAHOGANY	•	•	•	•
DARK HICKORY	•	•	•	•
ENGLISH WALNUT®	•	•	•	•
CYPRESS®	•	•	•	•

Installation Preparation

Follow these installation preparation best practices to ensure a successful installation of TimberTech Closed-Joint Cladding:

- Prior to installation, be sure the wall is structurally sound, weather-tight, stud locations are identified and marked, and any protruding screws, nails, or staples are removed or pounded in.
- Ensure the finished installation is flat and even by using shims or a planer on wood furring strips. TimberTech Open-Joint Cladding will conform to undulations in the wall.
- For low profile sheathing installation, recommended furring is 1/2" x 2" plywood strips wrapped with TimberTech Joist tape."
- Use maximum spacing between furring strips of 16" on-center.
- TimberTech Closed-Joint Cladding is a one-sided product and must be installed with the grain side out.

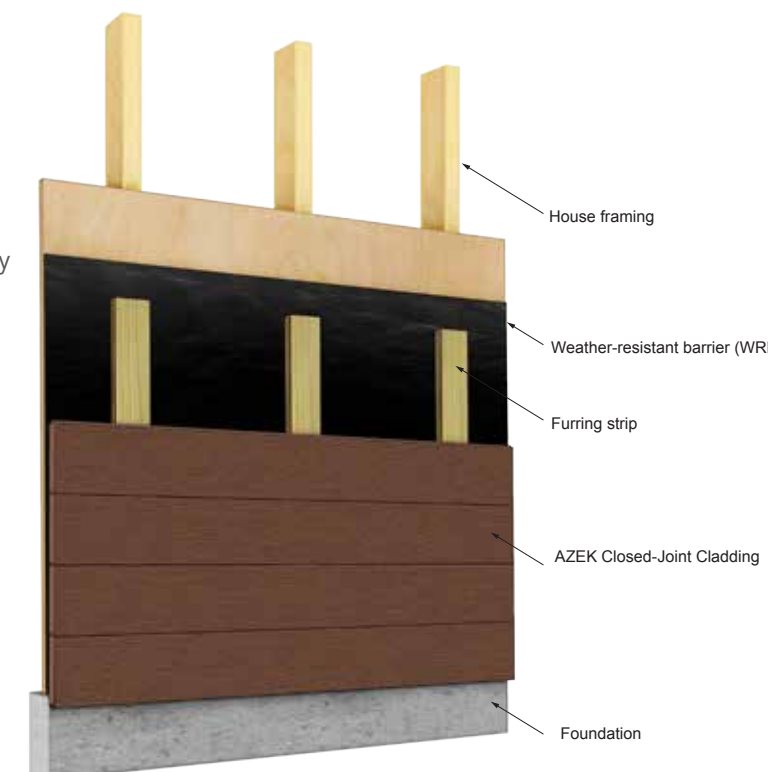

Expansion and Contraction

TimberTech Closed-Joint Cladding will expand and contract with changes in temperature, unlike wood which fluctuates with moisture. The expansion and contraction encountered may result in slight gaps at the board ends or splice joints. To help minimize these gaps, follow these best practices:

- Install the TimberTech Closed-Joint Cladding boards when they are as cool as possible. Avoid leaving them in direct sunlight prior to installation.
- Install boards cut to length immediately after cutting them.
- Cut all factory edges to ensure a clean, square cut, and install butt joints tight at all temperatures. Do not leave a gap.
- Leave a minimum 1/8" gap around all protrusions, boxes and fixtures. When notching or cutting out product to fit around the protrusions create a radius corner to limit stress. Install 2x4 furring strips around all protrusions and fasten the Cladding boards within 1/2" of cut edges.

Fasteners

- Use 2 1/2" and 2" Cortex® hidden fasteners available in color matching, or stainless steel fasteners for Vintage and Landmark collections are available (use 2" when installing into 2x4 pressure treated furring strips over a masonry wall).
- For salt water coastal applications, we suggest using the above minimum fastener requirements in 316 stainless steel.
- For masonry walls, use 1-5/8" Cortex Drillers installed into minimum 18-gauge steel channel. The steel should have a minimum yield strength of 33 ksi. 2x4 furring can also be installed over a masonry wall using 2" cortex. AZEK is not responsible for installation of furring to exterior wall.
- AZEK does not recommend any fastener that is not explicitly stated in this installation guide. Use of any alternative fastener does not void the AZEK warranty; however, if a cladding failure is caused by using one of these alternative fastening methods, any corresponding claims will be denied.
- AZEK strongly recommends using the fasteners outlined above. Other fasteners have not been tested and may limit the performance of the product and installation.

Fastening Schedule

3-1/8" Width Fastening

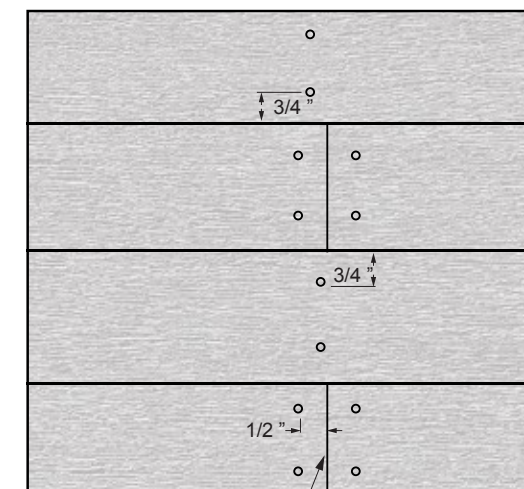

Install butt joints tight

Main Course:

- Use a minimum of 2 fasteners into each 16" on-center furring strip between the ends of the board.
- Position fasteners 3/4" from each side of the board.

Board Ends:

- Use a minimum of 2 fasteners into the furring strip on the ends of each board.
- Fasteners need to be placed within 1/2" from the ends, with 2 fasteners 3/4" from the edges.
- Drive fasteners perpendicular into furring strips. Do not angle.

5-1/2" Width Fastening

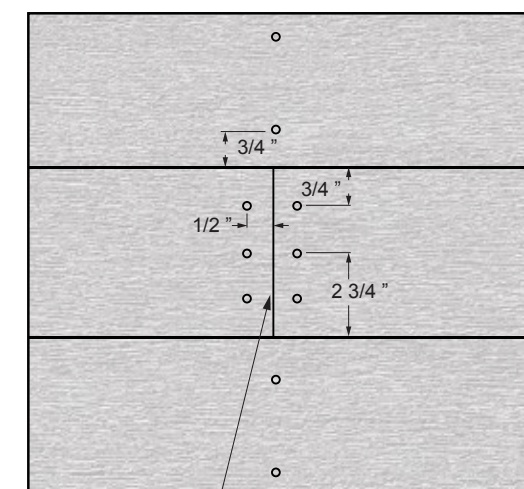

Install butt joints tight

Main Course:

- Use a minimum of 2 fasteners into each 16" on-center furring strip between the ends of the board.
- Position fasteners 3/4" from each side of the board.

Board Ends:

- Use a minimum of 3 fasteners into the furring strip on the ends of each board.
- Fasteners need to be placed within 1/2" from the ends, with 2 fasteners 3/4" from the edges and 1 fastener in the middle.
- Drive fasteners perpendicular into furring strips. Do not angle.

HORIZONTAL APPLICATION

1 Furring Strips

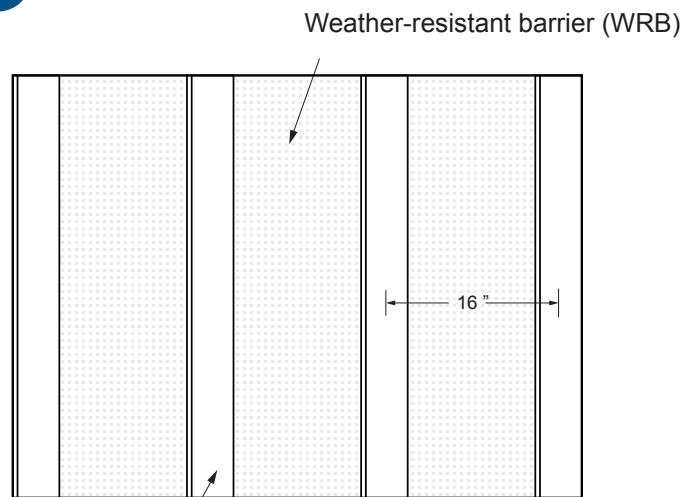

Min 1/2" x 2" furring. Must use plywood furring.
Warning: do not use OSB as a furring strip.

! Important

The wall or furring strips may move over time due to settling of the ground or building, age of the building, or expansion and contraction from moisture or temperature. To avoid wicking water into furring strips leave a gap to grade or use furring strips approved for ground contact.

- Attach min 1/2" x 2" plywood furring against the WRB or weather-tight wall. Warning: Do not use OSB as a furring strip.
- Use a maximum spacing of 16" on-center between furring strips.
- For wood framing, secure the furring strips into studs using suitable fasteners.
- For masonry construction, secure the steel channel to the masonry wall with suitable masonry fasteners.
- TimberTech joist tape to wrap plywood furring strips to protect furring from moisture.

! Important

After the furring members are installed, run string lines to ensure the faces of the furring strips are in plane. TimberTech Closed-Joint Cladding will contour to undulation in the furring strips. It may be necessary to shim or plane the furring strips due to thickness variations in lumber, or variations in the wall to which the furring strips are attached.

HORIZONTAL APPLICATION

2 Starting Course & Fastening

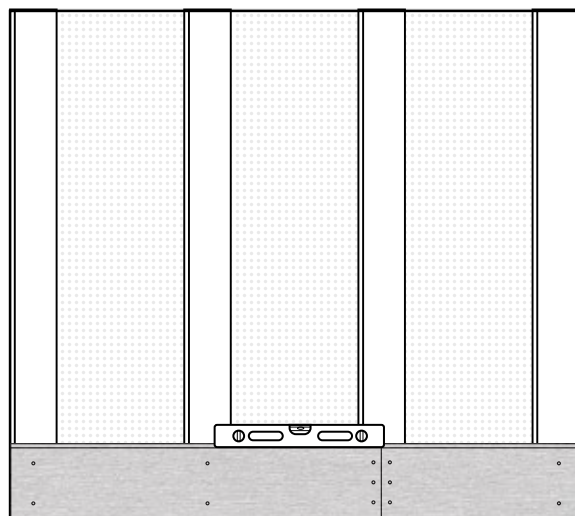

- Choose the starting location of the first course. Position the board with the tongue facing up and ensure it is level prior to fastening.
- For solid wood furring/sheathing assemblies, use the recommended fasteners and fastener lengths, with a minimum penetration into the sheathing assembly 1-1/4".
- The multi-width offering of TimberTech Closed-Joint Cladding has varying fastening schedules outlined on pages 5. It is important to fasten each width according to this fastening schedule.
- Fasten from the center out, or from one end to the other. Do not fasten each end and then fasten to the middle.
- Install all butt joints tight no matter the temperature.
- Frequently check for level as additional boards are installed up the wall.

HORIZONTAL APPLICATION

3 Spacing of Boards

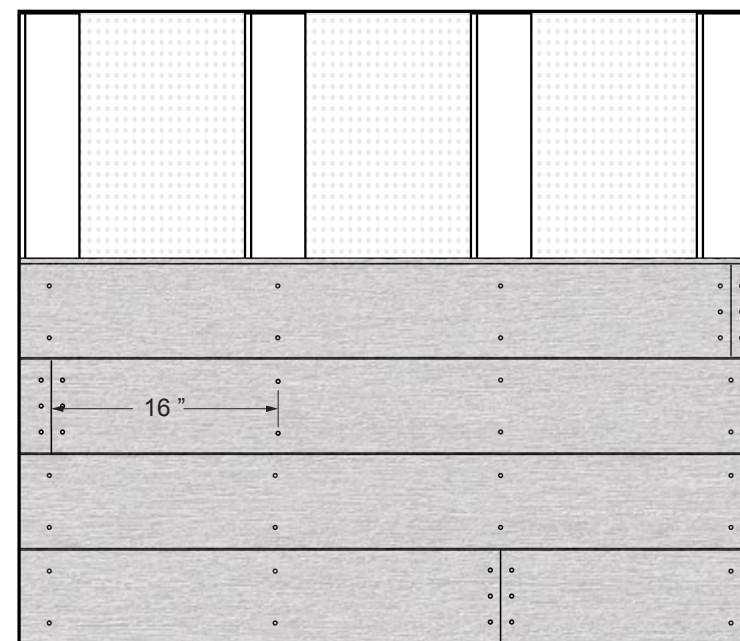

- Place the next course of Cladding with the groove setting onto the tongue of the course below.
- Fasten the course as outlined in the fastening schedule on page 5.
- To minimize the stress on individual furring strips, stagger butt joints across multiple furring strips. For best practices, stagger butt joints 32" from one course to the next.
- If a butt joint is necessary, always center it over a 1/2" x 3" plywood furring strip.

HORIZONTAL APPLICATION

4 Adjoining Walls

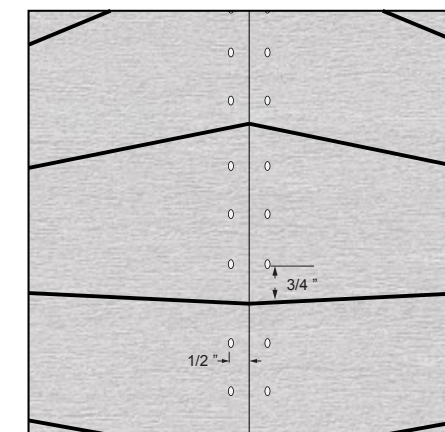
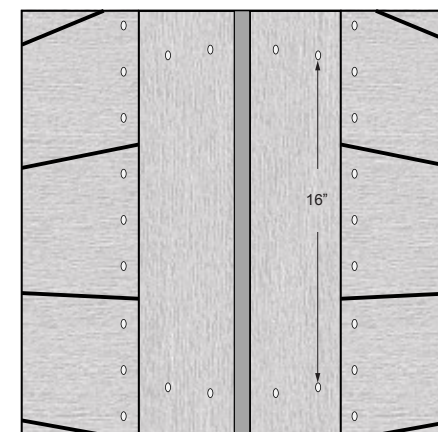

- For use on adjoining walls, be sure to check the level of each course frequently.
- TimberTech Closed-Joint Cladding can be installed with mitered corners. For best results, build out the corners with additional furring strips so the cladding can be fastened close to the ends.
- Additional furring may also be needed around wall openings such as doors and windows.
- Vertical outside corners may be constructed using TimberTech Open-Joint Cladding boards (square shouldered) running vertically, or with AZEK Trim, AZEK Cornerboards, or aluminum corner profiles.
- Vertical outside corners created with Cladding, Trim or Cornerboards must be furred out and fastened with 2 fasteners every 16".

5 Trimming Windows & Doors

HORIZONTAL APPLICATION

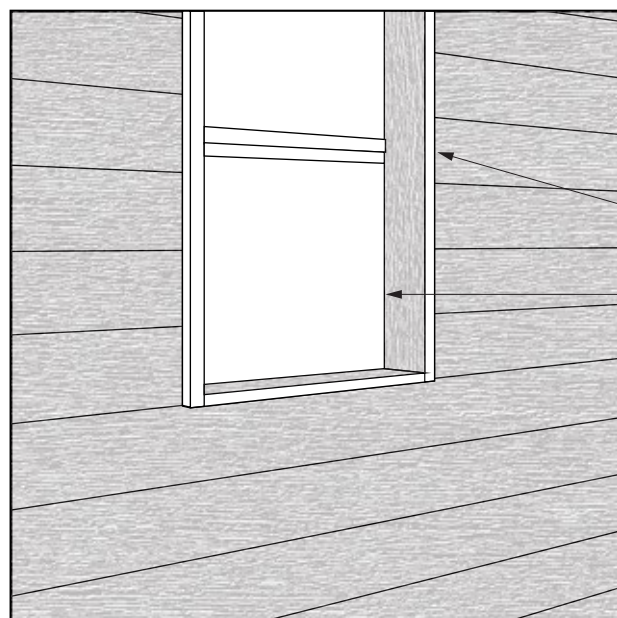

- TimberTech Open-Joint Cladding boards or AZEK Trim can be used as a casing around windows or doors. Using Closed-Joint Cladding boards will show an exposed groove.
- Factory edge facing outwards
- Rip cut edge facing inwards
- The example shown on the left is using an TimberTech Open-Joint Cladding board (square shouldered) that was rip cut to width as a side jam extension. The factory edge is installed facing outward and the rip cut edge toward the interior of the building (not exposed).
- Window jam extensions created with Cladding or Trim must be fastened with 2 fasteners every 16" and within 1/2" of each end cut.

1 Furring Strips

VERTICAL APPLICATION

- First, attach minimum 1/2" thick plywood furring strips vertically over a WRB or weather-tight wall (furring width minimum 2").
- Use a maximum spacing of 16" on center between furring strips, attached to structural framing members.
- After initial vertical furring strips are installed, attach treated 2x4 furring strips 16" on center horizontally thru the vertical furring strips and into structural framing members.
- For masonry construction, steel hat channel with min 1" separation from exterior wall can be used in both horizontal and vertical installations. If wood furring is used over a masonry wall, the total furring must be minimum 1-1/4".
- For proper fastener type and placement refer to your fastener manufacturer.

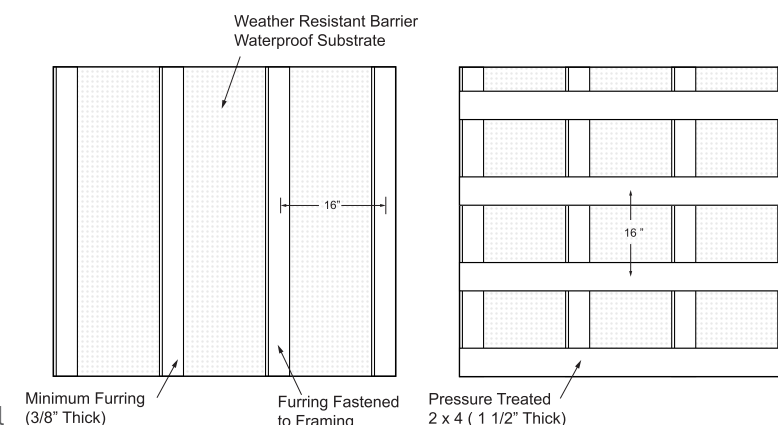

! Important

To avoid wicking water into furring strips leave a gap to grade or use furring strips approved for ground contact.

! Important

After the furring members are installed, run string lines to ensure the faces of the furring strips are in plane. TimberTech Closed-Joint Cladding will contour to undulation in the furring strips. It may be necessary to shim or plan the furring strips due to thickness variations in lumber, or variations in the wall to which the furring strips are attached.

2 Starting Course & Fastening

VERTICAL APPLICATION

- Choose the starting location of the first course. Position the board with the tongue facing up and ensure it is plumb prior to fastening.
- Use the recommended fasteners and fastener lengths, with a minimum penetration into the furring strips of 1-1/4".
- The multi-width offering of TimberTech Closed-Joint Cladding has varying fastening schedules outlined on pages 5. It is important to fasten each width according to this fastening schedule.
- Fasten from the center out, or from one end to the other. Do not fasten each end and then fasten to the middle.
- Install all butt joints tight no matter the temperature.
- Check for plumb as boards are installed along the wall.

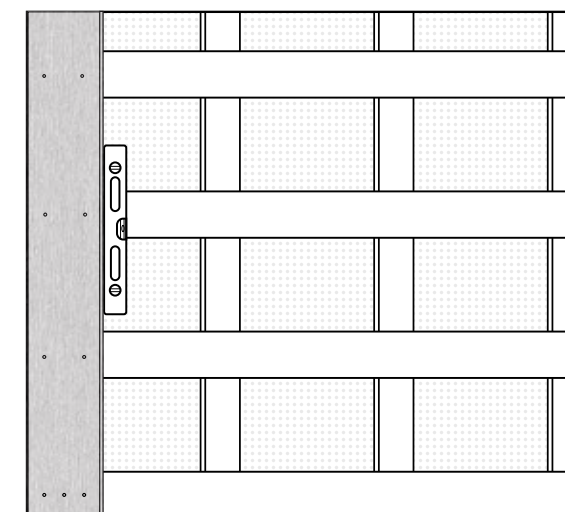

3 Spacing of Boards

VERTICAL APPLICATION

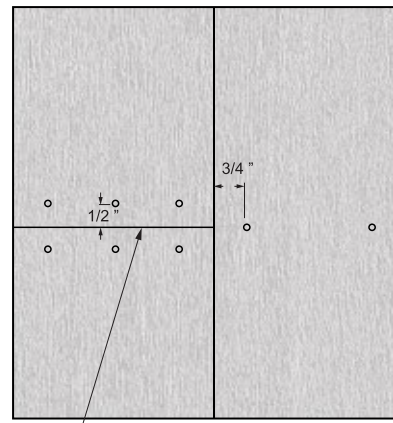
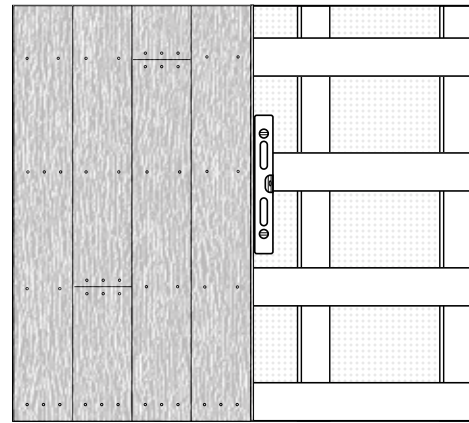

Install butt joints tight

- Place the next course of Cladding with the groove setting onto the tongue of the course below.
- Fasten the course as outlined in the fastening schedule on page 5.
- To minimize the stress on individual furring strips, stagger butt joints across multiple furring strips. For best practices, stagger butt joints 32" from one course to the next.
- If a butt joint is necessary, always center it over a 2x4 furring strip.

4 Adjoining Walls

VERTICAL APPLICATION

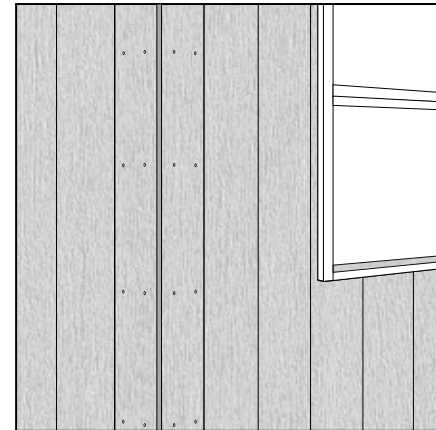
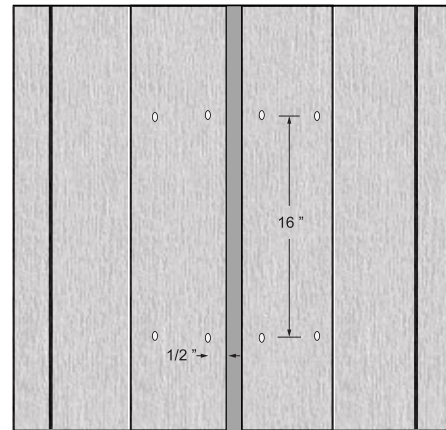

- For use on adjoining walls, but sure to check the level of each course frequently.
- TimberTech Closed-Joint Cladding can be installed with mitered corners. For best results, build out the corners with additional furring strips so the cladding can be fastened close to the ends.
- Additional furring may also be needed around wall openings such as doors and windows.
- Vertical outside corners may be constructed using TimberTech Open-Joint Cladding boards (square shouldered) running vertically, or with AZEK Trim, AZEK Cornerboards, or aluminum corner profiles.
- Vertical outside corners created with Cladding, Trim or Cornerboards must be furred out and fastened with 2 fasteners every 16".

5 Trimming Windows & Doors

VERTICAL APPLICATION

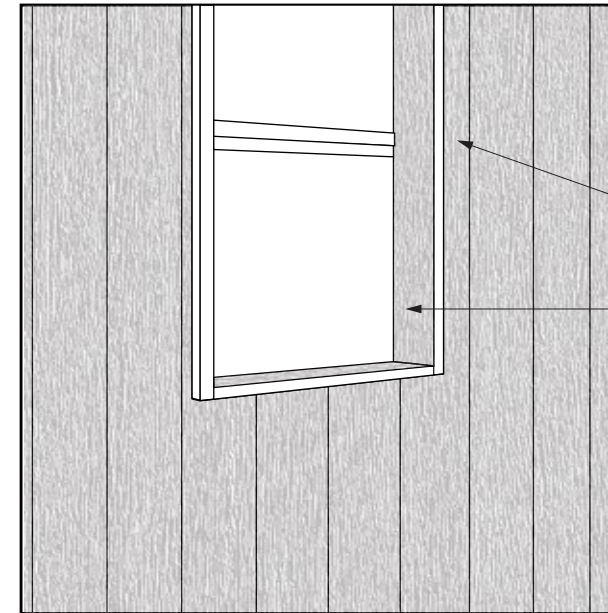

- TimberTech Open-Joint Cladding boards or AZEK Trim can be used as a casing around windows or doors. Using Closed-Joint Cladding boards will show an exposed groove.

Factory Edge Facing Outwards

Rip Cut Edge Facing Inwards

- The example shown on the left is using an TimberTech Open-Joint Cladding board (square shouldered) that was rip cut to width as a side jam extension. The factory edge is installed facing outward and the rip cut edge toward the interior of the building (not exposed).
- Window jam extensions created with Cladding or Trim must be fastened with 2 fasteners every 16" and within 1/2" of each end cut.

Storage & Handling

- Store TimberTech Closed-Joint Cladding on a flat and level surface.
- Store products in a cool, shady area prior to installation.
- Do not stack bundles over 8 units high.
- Always leave factory applied protective wrap. If stored outdoors, the product must be covered with non-translucent material.
- Use care when handling product with a forklift as forks can easily damage the material.
- If banding is used, use protective corners to prevent indents from the bands.
- Avoid storing TimberTech Closed-Joint Cladding in areas of excessive heat, such as on top of asphalt.



Excessive Construction Debris

It is important during construction that TimberTech Closed-Joint Cladding products stay clear from excessive build-up of dirt, sand, and dust from tile, concrete, landscape blocks, or any other masonry products. If these materials are not removed immediately, the cladding surface will become difficult to clean and can potentially damage the cladding's surface finish.

Do not use TimberTech Closed-Joint Cladding products as a work surface.

If a build-up does occur please refer to the Care and Cleaning section in the installation guidelines or website www.AZEKexteriors.com.

Considerations

- Advanced PVC Deck is designed to mimic the look of real wood, and like real wood, there will be a slight difference in color and grain pattern from board to board. This is intentional and part of the manufacturing process, giving Advanced PVC Deck the most realistic and wood-like appearance possible. This variation is purely aesthetic and does not or will not affect the performance of the product. When working with multiple units of decking, consider pulling boards randomly to mix rather than completing one unit at a time. It is always a good practice to layout deck boards in different lighting conditions/angles before final fastening.
- Depending on the environmental conditions, TimberTech Closed-Joint Cladding colors may appear to lighten over time as part of a natural weathering process.
- Please be aware that excessive heat build on the surface of AZEK products from external sources such as, but not limited to, fire or reflection of sunlight can potentially lead to damage. For example, sunlight which may be reflected by low-emissivity (Low-E) glass can potentially lead to damage of exterior building products, including TimberTech Closed-Joint Cladding and AZEK Trim, due to elevation of surface temperatures which far exceed that of normal exposure of the same materials to direct sunlight. Possible damage by such reflected concentrated light may include melting, sagging, warping, distortion, surface discoloration, increased expansion or contraction, and unusual weathering.
- Static build-up is a natural occurring phenomenon that can occur with many plastic-based products including PVC Cladding. It could occur with AZEK products under the right conditions.
- Although TimberTech Closed-Joint Cladding products are cooler to the touch than many other cladding products in similar colors, all cladding products will get hot in the sun. Additionally, generally speaking, the darker the color, the hotter it will feel.
- Always remove job-site dust, clay, dirt, mud, and other construction products from TimberTech Closed-Joint Cladding quickly. Do not allow construction dirt and debris to sit on the surface.
- **IMPORTANT:** Do not allow airborne dust from concrete, landscape blocks, or any masonry products to accumulate on the TimberTech Closed-Joint Cladding surface as it may damage the surface. Do not cut any products on or near TimberTech Closed-Joint Cladding.

Care & Maintenance

To keep your TimberTech Closed-Joint Cladding looking its best:

- Some products, such as sunblock or insect repellent, contain chemicals that may alter the surface of TimberTech Closed-Joint Cladding and AZEK Trim. Check product labels and consult with the manufacturer as to product compatibility with plastic materials prior to use on or near TimberTech Closed-Joint Cladding or Trim products.
- Do not get any PVC glue or similar product on the surface of any TimberTech Closed-Joint Cladding or Trim products as it may discolor and permanently damage the surface.
- To clean TimberTech Closed-Joint Cladding, use TimberTech DeckCleaner™ with a stiff natural fiber brush, or another all purpose cleaner such as Simple® Green.
- Be sure to thoroughly rinse after cleaning to prevent discoloration that could occur with residual cleaner drying on surface
- Always read the cleaning products manufacturer's specific information before using any product on your TimberTech Closed-Joint Cladding and follow their instructions. It is also a good idea to test the cleaner on a scrap piece or inconspicuous area of the wall to make sure it does not harm the surface.
- **WARNING:** Keep children and pets away from cleaning products on the surface of Open-Joint Cladding until it is dry.
- *Note that composite deck and composite cladding cleaners such as Corte Clean®, Thompson's® Water Seal® Oxy Action, Olympic® Premium Deck Cleaner, or other cleaners specified as composite deck cleaners, in powder or liquid form, SHOULD NOT be used with TimberTech Closed-Joint Cladding or Trim. TimberTech Closed-Joint Cladding is a PVC-based polymer, not a wood/plastic composite.
- These guidelines may not encompass all installation, care and maintenance topics. For additional questions about TimberTech Closed-Joint Cladding installation, care or maintenance, call 1-800-901-3545.

Warranty

AZEK Building Products are made exclusively from technologically advanced materials designed to provide years of enjoyment. TimberTech Closed-Joint Cladding products are covered by a Lifetime Limited Warranty for residential applications and a 30-year Limited Warranty for commercial applications. The warranty covers certain defects resulting in splitting, cupping, splintering, blistering, peeling, flaking, cracking, rotting or structural damage from termites or fungal decay, as further described in the Limited Warranty. TimberTech® Closed-Joint Cladding products are also covered by a 50 year limited residential fade and stain warranty and a 30 year limited commercial fade and stain warranty. Visit AZEKexteriors.com/warranty to view complete warranty information.

The diagrams and instructions in this brochure are for illustration purposes only and are not meant to replace a licensed professional. Any construction or use of the product must be in accordance with all local zoning and/or building codes. The consumer assumes all risks and liability associated with the construction or use of this product. The consumer or contractor should take all necessary steps to ensure the safety of everyone involved in the project, including, but not limited to, wearing the appropriate safety equipment. Except as contained in the written limited warranties, AZEK does not provide any other warranty, either express or implied, and shall not be liable for any damages, including consequential damages.

AZEK[®]

EXTERIORS

TimberTech[®]

BY AZEK[®]

AZEK Building Products LLC and its affiliates
1330 West Fulton, Suite 350
Chicago, Illinois 60607

AZEKexteriors.com • 1-800-901-3545



TimberTech® Open-Joint Cladding Install Guide

Tools Required	2
Products	3
Installation Preparation	3
Expansion and Contraction	4
Fasteners	4
Fastening Schedule	5-6
Horizontal Application	7-9
Vertical Application	10-12
Storage & Handling, Considerations	13
Care and Maintenance	14

TOOLS REQUIRED

TimberTech® Open-Joint Cladding should be installed using good building principals and in accordance with local building codes and the installation guidelines included below. AZEK® Building Products LLC and its affiliates, successors and assigns accepts no liability or responsibility for the improper installation of this product. TimberTech Open-Joint Cladding may not be suitable for every application and it is the sole responsibility of the installer to be sure any products are a fit for the intended use. Since all installations are unique, it is also the installer's responsibility to determine specific requirements for each application. AZEK recommends that all applications be reviewed by a licensed architect, engineer or local building official before installation. If you have any questions or need further assistance, please call AZEK Customer Service at 1-800-910-3545 our website at www.AZEKexteriors.com.

Tools Required

TimberTech Open-Joint Cladding can be installed with a minimum number of readily available tools. Many other tools are available that can be used for installation. All tools should be used per applicable manufacturers' instructions. Some of the basic tool requirements:

- Cordless Driver
- Carpenter Square
- Chalk Line
- Spacing Tools
- Tape Measure
- Miter Saw
- Jig Saw
- Chalk Line/String
- Level
- Safety Glasses

Use the jigsaw to cut around obstruction. For best results when cutting, use a power miter saw with a fine-toothed, carbide tipped finish trim blade (12"-100 tooth min. or 10"-80 tooth min.) For best results, and to minimize gapping, use boards 12' in length or less. Do not install 20' lengths as cladding. When working with AZEK products be sure to wear proper clothing and safety equipment. Safety glasses should be used during the entire installation process. Do not use any cordless saws.



Extreme Heat Warning

Be aware of excessive heat on the surface of AZEK products from external sources, such as but not limited to, fire or reflection of sunlight from energy-efficient window products. Low-emissivity (Low-E) glass can potentially harm AZEK products. Low-E glass is designed to prevent passive heat gain within a structure and can cause unusual heat build-up on exterior surfaces. This extreme elevation of surface temperatures, which exceeds that of normal exposure, can possibly cause AZEK products to melt, sag, warp, discolor, increase expansion/contraction, and accelerate weathering.

Current or potential AZEK customers that have concerns about possible damage by Low-E glass should contact the manufacturer of the product which contains Low-E glass for a solution to reduce or eliminate the effects of reflected sunlight.



Non Load Bearing Only

TimberTech Open-Joint Cladding is a non-structural cladding and cannot be used as a load bearing component of the wall.



Important

The outside wall of structure must be weather tight and up to code with a proper weather-resistant barrier or other weather-proofing product prior to installing TimberTech Open-Joint Cladding. AZEK Closed-Joint Cladding is not designed for nor intended to prevent water infiltration. It is the sole responsibility of the engineer, architect, and installer to ensure the design and installation of the wall and building are code compliant and weather-resistant behind TimberTech Open-Joint Cladding.

Products

TimberTech® Open-Joint Cladding Boards

(Grooved Boards Not Recommended)

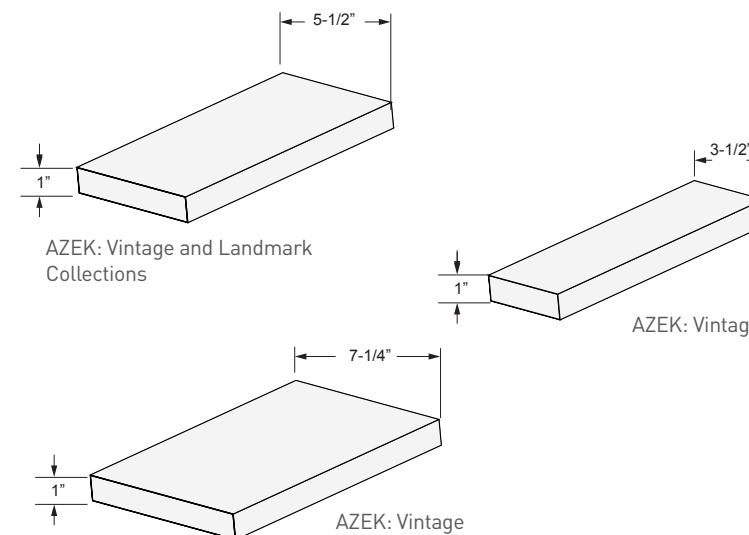

OPEN-JOINT CLADDING PRODUCTS	BOARD LENGTHS	
	12'	16'
5 1/2" Width		
VINTAGE COLLECTION®		•
LANDMARK COLLECTION		•
3 1/2" Width		
VINTAGE COLLECTION®	•	•
7 1/4" Width		
VINTAGE COLLECTION®	•	•

Installation Preparation

Follow these installation preparation best practices to ensure a successful installation of TimberTech Open-Joint Cladding:

- Prior to installation, be sure the wall is structurally sound, weather-tight, stud locations are identified and marked, and any protruding screws, nails, or staples are removed or pounded in.
- Ensure the finished installation is flat and even by using shims or a planer on wood furring strips. TimberTech Open-Joint Cladding will conform to undulations in the wall.
- For low profile sheathing installation, recommended furring is 1/2" x 2" plywood strips wrapped with TimberTech Joist tape.
- Use maximum spacing between furring strips of 16" on-center.
- TimberTech Open-Joint Cladding is a one-sided product and must be installed with the grain side out.

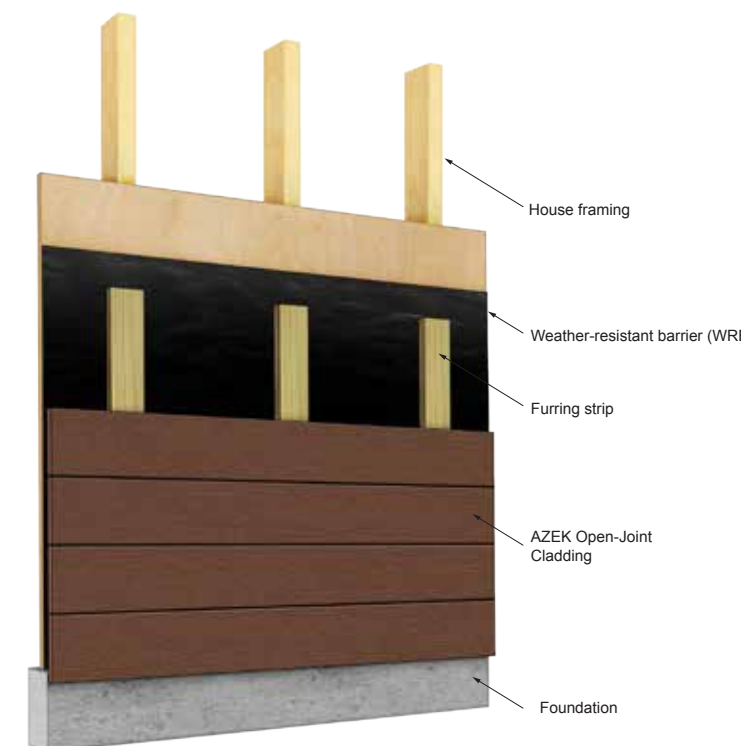

Expansion and Contraction

TimberTech Open-Joint Cladding will expand and contract with changes in temperature, unlike wood which fluctuates with moisture. The expansion and contraction encountered may result in slight gaps at the board ends or splice joints. To help minimize these gaps, follow these best practices:

- Install the TimberTech Open-Joint Cladding boards when they are as cool as possible. Avoid leaving them in direct sunlight prior to installation.
- Install boards cut to length immediately after cutting them.
- Cut all factory edges to ensure a clean, square cut, and install butt joints tight at all temperatures. Do not leave a gap.
- Leave a 1/8" gap between boards along the full length of the boards for proper airflow.
- Leave a minimum 1/8" gap around all protrusions, boxes and fixtures. When notching or cutting out product to fit around the protrusions create a radius corner to limit stress. Install 2x4 furring strips around all protrusions. and fasten the Cladding boards within 1/2" of cut edges.
- For best results, and to minimize gapping, use boards 12' in length or less. Do not install 20' lengths as cladding.

Fasteners

- Use 2 1/2" and 2" Cortex® hidden fasteners available in color matching, or stainless steel fasteners for Vintage, Harvest and Arbor are available (use 2" when installing into 2x4 pressure treated furring strips over a masonry wall).
- For salt water coastal applications, we suggest using the above minimum fastener requirements in 316 stainless steel.
- For masonry walls, use 1-5/8" Cortex Drillers installed into minimum 18-gauge steel channel. The steel should have a minimum yield strength of 33 ksi. 2x4 furring can also be installed over a masonry wall using 2" cortex. AZEK is not responsible for installation of furring to exterior wall.
- AZEK does not recommend any fastener that is not explicitly stated in this installation guide. Use of any alternative fastener does not void the AZEK warranty; however, if a cladding failure is caused by using one of these alternative fastening methods, any corresponding claims will be denied.
- AZEK strongly recommends using the fasteners outlined above. Other fasteners have not been tested and may limit the performance of the product and installation.

Fastening Schedule

5-1/2" Width Fastening

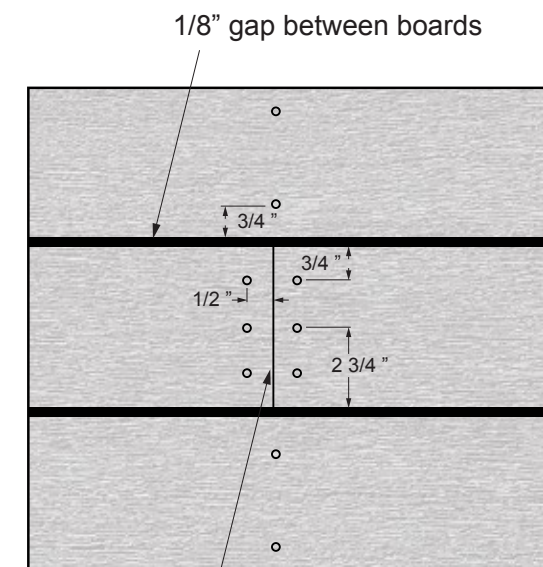

Main Course:

- Use a minimum of 2 fasteners into each 16" on-center furring strip between the ends of the board.
- Position fasteners 3/4" from each side of the board.

Board Ends:

- Use a minimum of 3 fasteners into the furring strip on the ends of each board.
- Fasteners need to be placed within 1/2" from the ends, with 2 fasteners 3/4" from the edges and 1 fastener in the middle.
- Drive fasteners perpendicular into furring strips. Do not angle.

3-1/2" Width Fastening

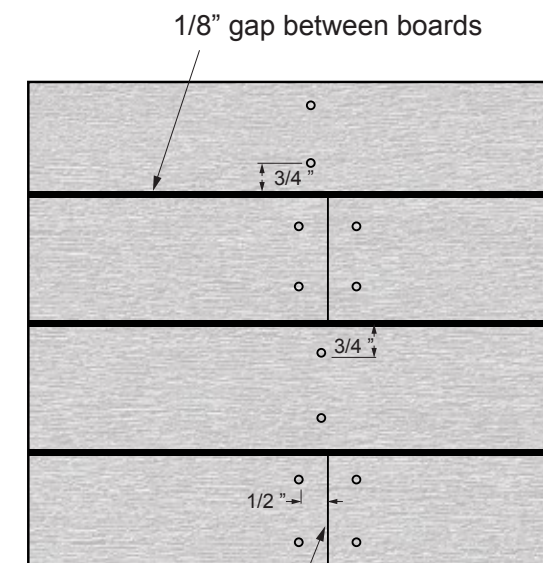

Main Course:

- Use a minimum of 2 fasteners into each 16" on-center furring strip between the ends of the board.
- Position fasteners 3/4" from each side of the board.

Board Ends:

- Use a minimum of 2 fasteners into the furring strip on the ends of each board.
- Fasteners need to be placed within 1/2" from the ends and 3/4" from both edges.
- Drive fasteners perpendicular into furring strips. Do not angle.

Install butt joints tight

Fastening Schedule

7-1/4" Width Fastening

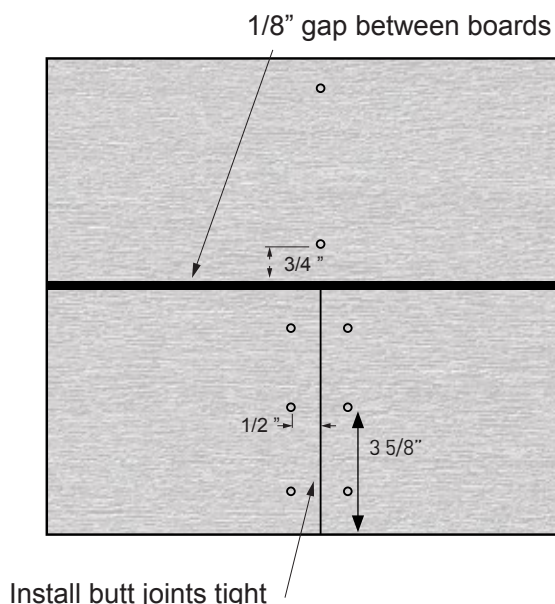

Main Course:

- Use a minimum of 2 fasteners into each 16" on-center furring strip between the ends of the board.
- Position fasteners 3/4" from each side of the board.

Board Ends:

- Use a minimum of 3 fasteners into the furring strip on the ends of each board.
- Fasteners need to be placed within 1/2" from the ends, with 2 fasteners 3/4" from the edges and 1 fastener in the middle.
- Drive fasteners perpendicular into furring strips. Do not angle.

1 Furring Strips

HORIZONTAL APPLICATION

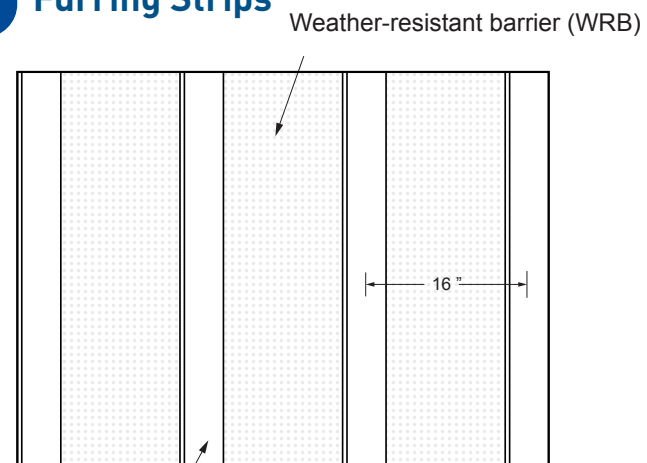

Min 1/2" x 2" furring. Must use plywood furring. Warning: do not use OSB as a furring strip.

Important

The wall or furring strips may move over time due to settling of the ground or building, age of the building, or expansion and contraction from moisture or temperature. To avoid wicking water into furring strips leave a gap to grade or use furring strips approved for ground contact.

Important

After the furring members are installed, run string lines to ensure the faces of the furring strips are in plane. TimberTech Open-Joint Cladding will contour to undulation in the furring strips. It may be necessary to shim or plane the furring strips due to thickness variations in lumber, or variations in the wall to which the furring strips are attached.

2 Starting Course & Fastening

HORIZONTAL APPLICATION

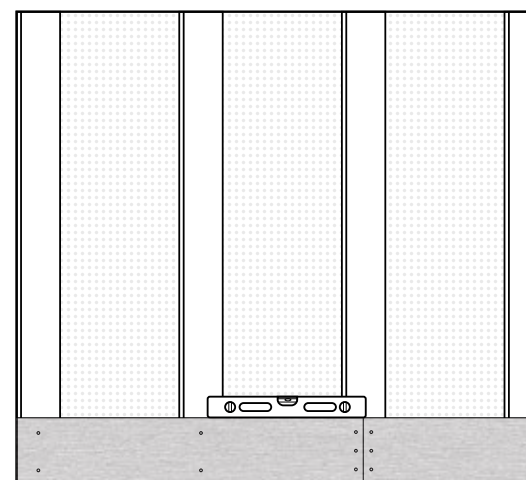

- Determine the starting location of the first course, hold the board in place and ensure it is level prior to fastening.
- For solid wood furring/sheathing assemblies, use the recommended fasteners and fastener lengths, with a minimum penetration into the sheathing assembly 1-1/4".
- The multi-width offering of TimberTech Open-Joint Cladding has varying fastening schedules outlined on pages 5 and 6. It is important to fasten each width according to this fastening schedule.
- Fasten from the center out, or from one end to the other. Do not fasten each end and then fasten to the middle.
- Install all butt joints tight no matter the temperature.
- Frequently check for level as additional boards are installed up the wall.

3 Spacing of Boards

HORIZONTAL APPLICATION

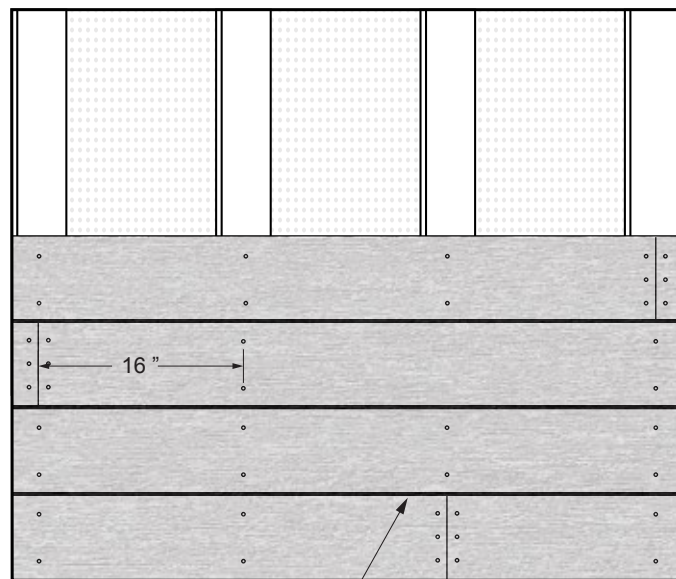

1/8" gap between courses

- In order to facilitate air circulation, leave a minimum 1/8" gap between board courses up the wall. However, butt joints must be installed tight.
- Use a spacer to create consistent gaps. Do not use a spacer that may damage the boards or that cannot be easily removed.
- To minimize the number of butt joints on a single furring strip, stagger butt joints across multiple furring strips.
- If a butt joint is necessary, be sure to center it over a furring strip.

4 Adjoining Walls

HORIZONTAL APPLICATION

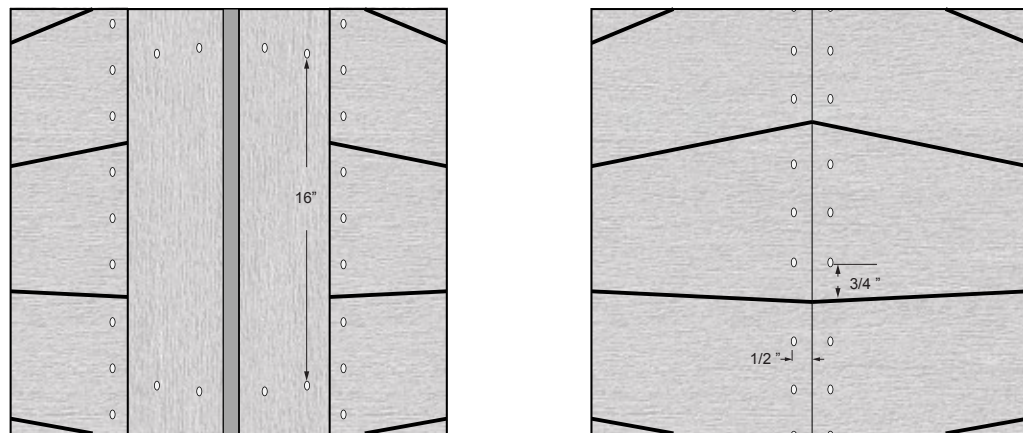

- For use on adjoining walls, but sure to check the level of each course frequently.
- TimberTech Open-Joint Cladding can be installed with mitered corners. For best results, build out the corners with additional furring strips so the cladding can be fastened close to the ends.
- Additional furring may also be needed around wall openings such as doors and windows.
- Vertical outside corners may be constructed using TimberTech Open-Joint Cladding boards being run vertical, or with AZEK Trim, AZEK Cornerboards, or aluminum corner profiles.
- Vertical outside corners created with Cladding, Trim or Cornerboards must be furred out and fastened with 2 fasteners every 16".

5 Trimming Windows & Doors

HORIZONTAL APPLICATION

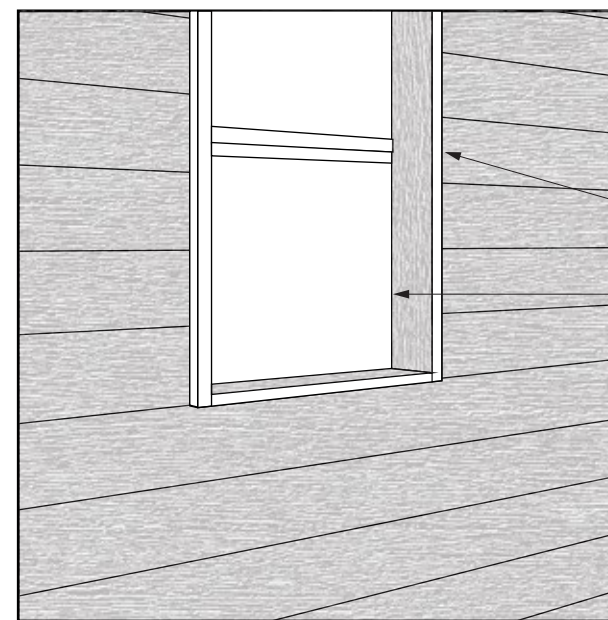

- TimberTech Open-Joint Cladding boards or AZEK Trim may also be used as a casing around windows or doors.

Factory edge facing outwards

Rip cut edge facing inwards

- The example shown on the left is using a TimberTech Open-Joint Cladding board that was rip cut to width as a side jam extension. The factory edge is installed facing outward and the rip cut edge toward the interior of the building (not exposed).
- Window jam extensions created with Cladding or Trim must be fastened with 2 fasteners every 16" and within 1/2" of each end cut.

1 Furring Strips

VERTICAL APPLICATION

- First, attach a minimum 1/2" thick plywood furring strips vertically over a WRB or weather-tight wall (furring width minimum 2")
- Use a maximum spacing of 16" on center between furring strips, attached to structural framing members.
- After initial vertical furring strips are installed, attach treated 2x4 furring strips 16" on center horizontally thru the vertical furring strips and into structural framing members.
- For masonry construction, steel hat channel with min 1" separation from exterior wall can be used in both horizontal and vertical installations. If wood furring is used over a masonry wall, the total furring must be minimum 1-1/4".
- For proper fastener type and placement refer to your fastener manufacturer.

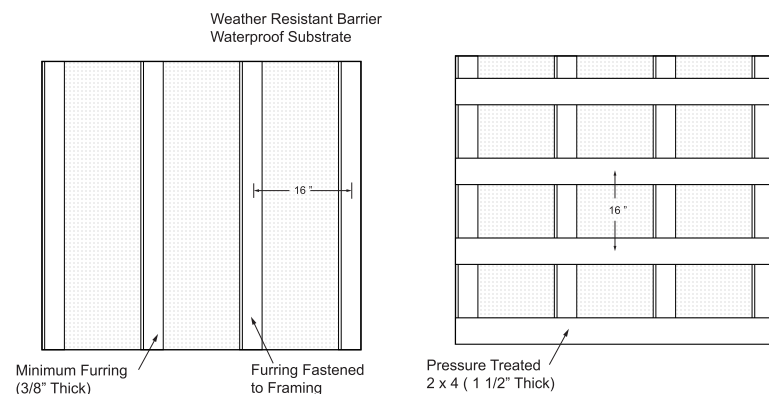

! Important

After the furring members are installed, run string lines to ensure the faces of the furring strips are in plane. TimberTech Open-Joint Cladding will contour to undulation in the furring strips. It may be necessary to shim or plan the furring strips due to thickness variations in lumber, or variations in the wall to which the furring strips are attached.

! Important

To avoid wicking water into furring strips leave a gap to grade or use furring strips approved for ground contact.

2 Starting Course & Fastening

VERTICAL APPLICATION

- Determine the starting location of the first course, hold the board in place and ensure it is plumb prior to fastening.
- Use the recommended fasteners and fastener lengths, with a minimum penetration into the furring strips of 1-1/4".
- The multi-width offering of TimberTech Open-Joint Cladding has varying fastening schedules outlined on pages 5 and 6. It is important to fasten each width according to this fastening schedule.
- Fasten from the center out, or from one end to the other. Do not fasten each end and then fasten to the middle.
- Install all butt joints tight no matter the temperature.
- Check for plumb as boards are installed along the wall.

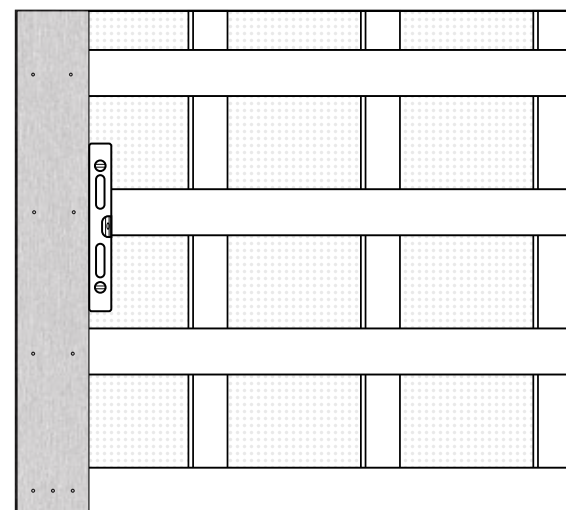

3 Spacing of Boards

VERTICAL APPLICATION

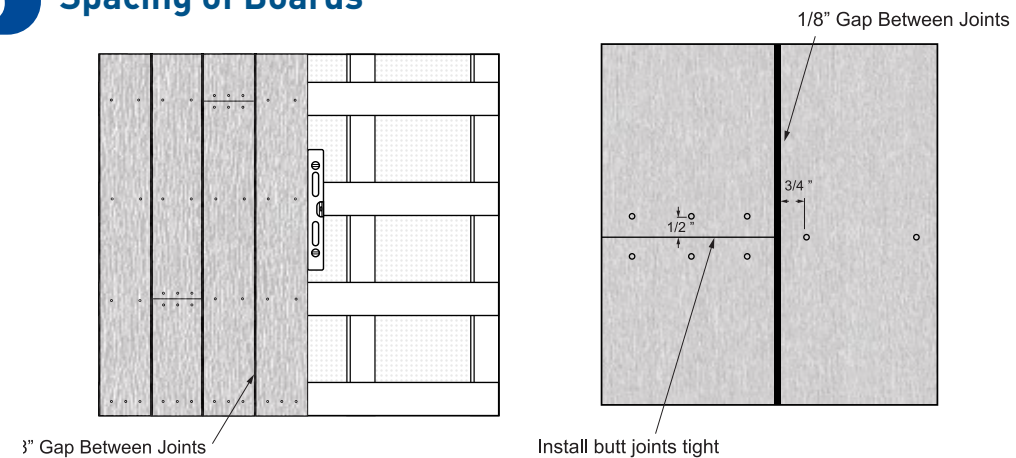

- In order to facilitate air circulation, leave a minimum 1/8" gap between board courses along the wall. However, butt joints must be installed tight.
- Use a spacer to create consistent gaps. Do not use a spacer that may damage the boards or that cannot be easily removed.
- To minimize the number of butt joints on a single furring strip, stagger butt joints across multiple furring strips.
- If a butt joint is necessary, be sure to center it over a 1/2" x 3" plywood furring strip.

4 Adjoining Walls

VERTICAL APPLICATION

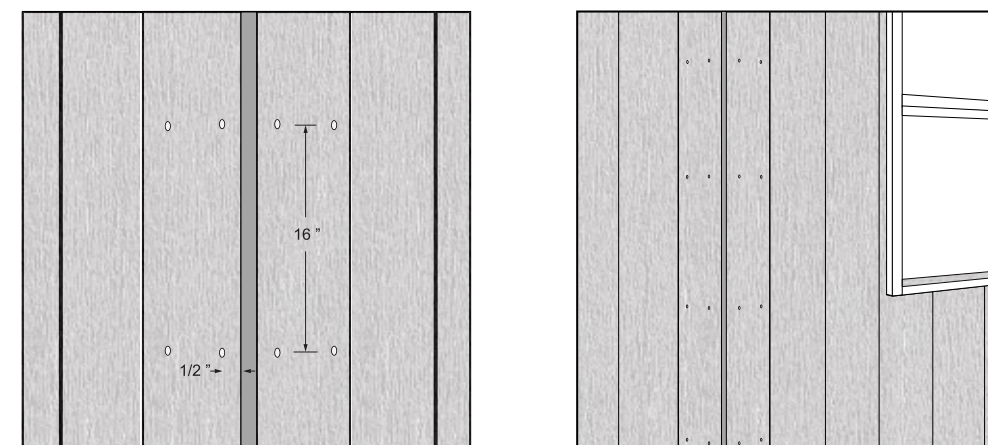

- For use on adjoining walls, but sure to check the level of each course frequently.
- TimberTech Open-Joint Cladding can be installed with mitered corners. For best results, build out the corners with additional furring strips so the cladding can be fastened close to the ends.
- Additional furring may also be needed around wall openings such as doors and windows.
- Vertical outside corners may be constructed using TimberTech Open-Joint Cladding boards being run vertical, or with AZEK Trim, AZEK Cornerboards, or aluminum corner profiles.
- Vertical outside corners created with Cladding, Trim or Cornerboards must be furred out and fastened with 2 fasteners every 16".

5 Trimming Windows & Doors

VERTICAL APPLICATION

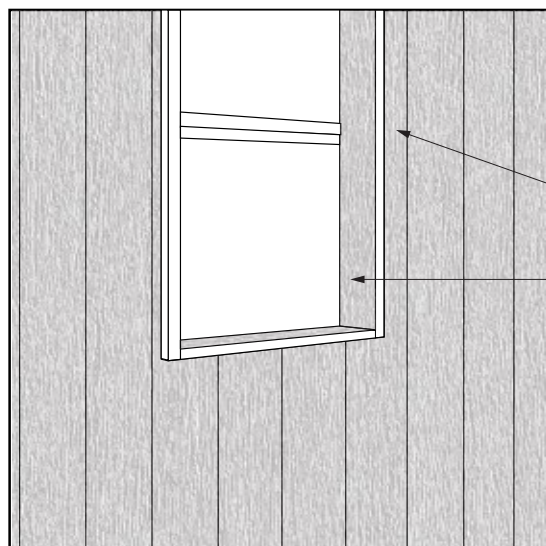

- TimberTech Open-Joint Cladding boards or AZEK Trim may also be used as a casing around windows or doors.

Factory Edge Facing Outwards

Rip Cut Edge Facing Inwards

- The example shown on the left is using an TimberTech Open-Joint Cladding board that was rip cut to width as a side jam extension. The factory edge is installed facing outward and the rip cut edge toward the interior of the building (not exposed).
- Window jam extensions created with Cladding or Trim must be fastened with 2 fasteners every 16" and within 1/2" of each end cut.

Storage & Handling

- Store TimberTech Open-Joint Cladding on a flat and level surface.
- Store products in a cool, shady area prior to installation.
- Do not stack bundles over 8 units high.
- Always leave factory applied protective wrap. If stored outdoors, the product must be covered with non-translucent material.
- Use care when handling product with a forklift as forks can easily damage the material.
- If banding is used, use protective corners to prevent indents from the bands.
- Avoid storing TimberTech Open-Joint Cladding in areas of excessive heat, such as on top of asphalt.



Excessive Construction Debris

It is important during construction that TimberTech Open-Joint Cladding products stay clear from excessive build-up of dirt, sand, and dust from tile, concrete, landscape blocks, or any other masonry products. If these materials are not removed immediately, the cladding surface will become difficult to clean and can potentially damage the cladding's surface finish.

Do not use TimberTech Open-Joint Cladding products as a work surface.

If a build-up does occur please refer to the Care and Cleaning section in the installation guidelines or website www.AZEKexteriors.com.

Considerations

- Advanced PVC Deck is designed to mimic the look of real wood, and like real wood, there will be a slight difference in color and grain pattern from board to board. This is intentional and part of the manufacturing process, giving Advanced PVC Deck the most realistic and wood-like appearance possible. This variation is purely aesthetic and does not or will not affect the performance of the product. When working with multiple units of decking, consider pulling boards randomly to mix rather than completing one unit at a time. It is always a good practice to layout deck boards in different lighting conditions/angles before final fastening.
- Depending on the environmental conditions, TimberTech Open-Joint Cladding colors may appear to lighten over time as part of a natural weathering process.
- Please be aware that excessive heat build on the surface of AZEK products from external sources such as, but not limited to, fire or reflection of sunlight can potentially lead to damage. For example, sunlight which may be reflected by low-emissivity (Low-E) glass can potentially lead to damage of exterior building products, including TimberTech Open-Joint Cladding and AZEK Trim, due to elevation of surface temperatures which far exceed that of normal exposure of the same materials to direct sunlight. Possible damage by such reflected concentrated light may include melting, sagging, warping, distortion, surface discoloration, increased expansion or contraction, and unusual weathering.
- Static build-up is a natural occurring phenomenon that can occur with many plastic-based products including PVC Cladding. It could occur with AZEK products under the right conditions.
- Although TimberTech Open-Joint Cladding products are cooler to the touch than many other cladding products in similar colors, all cladding products will get hot in the sun. Additionally, generally speaking, the darker the color, the hotter it will feel.
- Always remove job-site dust, clay, dirt, mud, and other construction products from TimberTech Open-Joint Cladding quickly. Do not allow construction dirt and debris to sit on the surface.
- **IMPORTANT:** Do not allow airborne dust from concrete, landscape blocks, or any masonry products to accumulate on the TimberTech Open-Joint Cladding surface as it may damage the surface. Do not cut any products on or near TimberTech Open-Joint Cladding.

AZEK[®]

EXTERIORS

TimberTech[®]
BY AZEK[®]

AZEK Building Products LLC and its affiliates
1330 West Fulton, Suite 350
Chicago, Illinois 60607
AZEKexteriors.com • 1-800-910-3545